

**RAJGARH TEA ESTATE**  
**(A Government of India Enterprise)**  
**P.O. & Dist : Dibrugarh, Assam 785675**

NOTICE INVITING TENDERS

**Rajgarh Tea Estate on behalf of ANDREW YULE & CO. LTD** invites e-Tender under two part system (**Part I: Techno-Commercial Bid and Part II: Price Bid**) from bona fide and reputed **Company/Firm** for **Renovation of Welfare Officer's Bungalow**, the details of which are available in Annexure-IV "Scope of Work / Technical Specification" as specified in this tender document.

Tender document may be downloaded from MSTC website [www.mstcecommerce.com/eprochome/aycl](http://www.mstcecommerce.com/eprochome/aycl) or [www.andrewyule.com](http://www.andrewyule.com). Corrigenda or clarifications, if any, shall be hosted on the above mentioned websites only. AYCL reserves the right to accept or reject any tender.

**Schedule of Tender**

1.	<b>TENDER NO.</b>	<b>RJ/CAPITAL/17-18/01</b> <b>Dated. : 13.10.2017</b>
2.	<b>MODE OF TENDER</b>	e-Procurement System Online submission of <b>Part I - Techno-Commercial Bid</b> and <b>Part II - Price Bid</b> through <a href="http://www.mstcecommerce.com/eprochome/aycl">www.mstcecommerce.com/eprochome/aycl</a> The intending bidders are required to submit their offer electronically through this e-tendering portal. <b>No physical tender is acceptable by AYCL/MSTC</b>
3.	<b>E-Tender No. / Event No.</b>	AYCL/TEA DIVISION/29/17-18/ET/155
4.	<b>Date of publication of e-Tender through publication MSTC/AYCL websites and Central Public Procurement Portal</b>	18.10.2017
5.	<b>Date of availability of NIT to the Vendors for downloading</b>	18.10.2017
6.	<b>Earnest Money and other document</b>	<b>"Earnest Money Deposit"</b> of Rs.4,500.00 <b>(Rupees Four thousand Five Hundred only)</b> may be paid by D.D. favouring <b>Andrew Yule &amp; Co Ltd.</b> A/c Rajgarh Tea Estate payable at Dibrugarh. <b>Other document as described in Annexure – I, Sl. No. 2</b>

7.	Last date of submission of EMD & other documents to Manager, Rajgarh Tea Estate with an email confirmation to Chief General Manager, Tea Division at kaustuv.roy@andrewyule.com	7.11.2017
8.	Date of Starting of e-Tender for submission of Online Techno-Commercial Bid and Price Bid at <a href="http://www.mstcecommerce.com/eprochome/aycl">www.mstcecommerce.com/eprochome/aycl</a>	To be intimated to the eligible vendor separately by email as well as through Corrigendum in the website.
9.	Date of closing of Online e-tender for submission of Techno-Commercial Bid & Price Bid at <a href="http://www.mstcecommerce.com/eprochome/aycl">www.mstcecommerce.com/eprochome/aycl</a>	To be intimated to the eligible vendor separately by email as well as through Corrigendum in the website.
10.	Date & time of opening of Part-I (Techno-Commercial Bid)	To be intimated to the eligible vendor separately by email as well as through Corrigendum in the website.
11.	Date & time of opening of Part-II (Price Bid )	To be intimated to the eligible vendor separately by email as well as through Corrigendum in the website.

**List of Annexure**

<b>Important Instructions for E-procurement -</b>	<b>Annexure-I</b>
<b>Notice Inviting Tender</b>	<b>Annexure-II</b>
<b>General Information-</b>	<b>Annexure-III</b>
<b>Scope of Work / Technical Specification/ General Terms&amp; Conditions</b>	<b>Annexure-IV</b>
<b>Bill of Materials</b>	<b>Annexure-V</b>
<b>Drawing</b>	<b>Annexure-VI</b>
<b>Price Sheet</b>	<b>Annexure -VII</b>

**RAJGARH TEA ESTATE  
(A Government of India Enterprise)**

**Important Instructions for E-procurement**

**Ref. E-Tender No.:** AYCL/TEA DIVISION/29/17-18/ET/155

**Ref. Tender No.:** RJ/CAPITAL/17-18/01

This is an e-procurement event of Rajgarh Tea Estate, Dibrugarh of *ANDREW YULE & COMPANY LTD Ltd.*

You are requested to read the Terms & Conditions (Annexure- III,IV) of this tender before submitting your online tender. Tenderers who do not comply with the Conditions with documentary proof (wherever required) will not qualify in the Tender for opening of Price Bid.

**1. Process of E-tender:**

A) **Registration:** The process involves vendor's registration with MSTC e-procurement portal which is free of cost. Only after registration, the vendor(s) can submit his/their bids electronically. Electronic Bidding for submission of Techno-Commercial Bid as well as Price Bid over the internet will be done. The Vendor should possess Class III signing type Digital Signature Certificate. Vendors are to make their own arrangement for bidding from a PC connected with Internet. MSTC is not responsible for making such arrangement. (Bids will not be recorded without Digital Signature).

**SPECIAL NOTE:** THE PRICE BID AND THE COMMERCIAL BID HAS TO BE SUBMITTED ONLINE AT [www.mstcecommerce.com/eprochome/aycl](http://www.mstcecommerce.com/eprochome/aycl)

- 1) Vendors are required to register themselves online with [www.mstcecommerce.com](http://www.mstcecommerce.com) → e-Procurement → PSU / Govt. depts. → Register as Vendor under AYCL- Filling up details and creating own user id and password → Submit.
- 2) Vendors will receive a system generated mail confirming their registration in their email which has been provided during filling the registration form.

In case of any clarification, please contact MSTC/AYCL (before the scheduled time of the e-Tender).

**Contact person for Techno Commercial clarification(ANDREW YULE & COMPANY LTD):**

1. Mr. Apurba Chutia  
Manager,  
Rajgarh Tea Estate, Dibrugarh, Assam-7856611  
Mobile No: 9435515705  
Email: yule.rajgarh@gmail.com

**Contact person (E-Commerce, MSTC Ltd):**

1. Mr. Arindam Bhattacharjee  
Mobile No: 09330102643  
Email: arindam@mstcindia.co.in

2) Mr. Sabyasachi Mukherjee  
Mobile- 07278030407  
Email:smukherjee@mstcindia.co.in

3. Ms Sumona Maity  
Mobile-09831155225  
Email: smaity@mstcindia.co.in  
Landline: (033) 22901004

**System Requirement:**

- i) Windows XP-SP3 or above / Windows 7 Operating System
- ii) IE-7 or above Internet browser.
- iii) Signing & Encryption type digital signature
- iv) JRE 7 update 79 software to be downloaded and installed in the system. Security level should be medium
- v) To enable ALL active X controls and disable 'use pop up blocker' under Tools → Internet OpJons → custom level (Please run IE settings from the page [www.mstcecommerce.com](http://www.mstcecommerce.com) once)

2. **Part-I: Submission of EMD & other Documents:**

Within specified Date & time the vendor must submit the following documents to the Manager, Rajgarh Tea Estate Dist : Dibrugarh , Assam 7856611. Off-line.

- Earnest Money of Rs.4,500.00 (Rupees Four Thousand Five Hundred) by Demand Draft favouring Andrew Yule & Co. Ltd. A/C Rajgarh Tea Estate, Payable at Dibrugarh.
- General information, under Annexure-III complete in all respect along with desired information and document.
- Acceptance of Scope of Work/Technical Specification, under Annexure-IV along with relevant information and documents without Price Sheet.
- Technical specification sheet, with all desired details, duly signed and stamped as token of acceptance.
- Intending Bidders may visit the site before submission of the Off-Line documents at their own cost.

In case of failure to submit the EMD and other document within the stipulated time, the Tender may be rejected.

**Part-II: Online Bid submission: On the basis of submission of EMD and other Documents at Rajgarh Tea Estate, Dibrugarh, Assam the list of vendors who will participate in online Techno commercial and price bid submission will be finalized .Only those qualified bidders will be eligible to submit Online Techno-commercial and price bid.**

**Bidding in e-Tender:**

- a. No interest will be paid on EMD. EMD of the unsuccessful bidder(s) will be refunded by Rajgarh Tea Estate. EMD to be paid along with the Document within the last date as mentioned in SOT.
- b. The process involves Electronic Bidding for submission of Techno Commercial Bid as well as Price Bid.
- c. The bidder(s) who have submitted the EMD and documents to Rajgarh Tea Estate will be short listed by Manager, Rajgarh Tea Estate and those qualified bidders can only submit their Techno Commercial Bids and Price Bid through internet in MSTC website [www.mstcecommerce.com](http://www.mstcecommerce.com) → e-procurement → Psu / Govt depts. → Login under AYCL → My Menu → Auction Floor Manager → live event → Selection of the live event.
- d. The bidder should allow to run an application namely enApple by accepting the risk and clicking on run. This exercise has to be done twice immediately after opening of Bid floor. Then they have to fill up Common terms /Commercial specification and save the same. After that clicking on the Techno-Commercial bid, if this application is not run then the bidder will not be able to save / submit his Techno-Commercial bid.
- e. After filling the Techno-Commercial Bid, bidder should click 'save' for recording their Techno-Commercial bid. Once the same is done, the Price Bid link becomes active and the same has to be filled up and then bidder should click on "**Save**" to record their Price Bid. Then once both the Techno-Commercial bid & Price Bid has been saved, the bidder can click on the "**Submit**" button to register their bid.
- f. Vendors are instructed to use link in **My Menu** to **Upload Documents** in document library. Multiple documents can be uploaded. Maximum size of single document for upload is 5 MB.
- g. Once documents are uploaded in the library, vendors can attach documents through *Attach Document* link against the particular tender. For further assistance please follow instructions of vendor guide.
- h. In all cases, bidder should use their own ID and Password along with Digital Signature at the time of submission of their bid.
- i. During the entire e-tender process, the bidders will remain completely anonymous to one another and also to everybody else.

- j. The e-tender floor shall remain open from the pre-announced date & time and for as much duration as mentioned above.
- k. Techno-Commercial bid will be opened electronically on specified date and time as given in the NIT. Bidder(s) can download Technical Comparative statement.
- l. Price bid will be opened electronically on specified date and time given in the NIT. Bidder(s) can download Price Comparative statement.
- m. All entries in the tender should be entered in online Technical & Commercial Formats without any ambiguity.
- n. All electronic bids submitted during the e-tender process shall be legally binding on the bidder. Any bid will be considered as the valid bid offered by that bidder and acceptance of the same by the Buyer will form a binding contract between Buyer and the Bidder for execution of supply. Such successful tenderer shall be called hereafter **SUPPLIER**.
- o. It is mandatory that all the bids are submitted with Digital Signature Certificate otherwise the same will not be accepted by the system.
- p. Buyer reserves the right to cancel or reject or accept or withdraw or extend the tender in full or part as the case may be without assigning any reason thereof.
- q. No deviation of the terms and conditions of the tender document is acceptable. Submission of bid in the e-tender floor by any bidder confirms his acceptance of terms & conditions for the tender.
- r. Unit of Measure (UOM) is indicated in the e-tender Floor. Rate to be quoted should be in Indian Rupee as per UOM indicated in the e-tender floor/tender document.

E-tender cannot be accessed after the due date and time mentioned in NIT.

All notices / corrigendum and correspondence to the bidder(s) shall be sent by email only during the process till finalization of tender by RAJGARH TEA ESTATE/ANDREW YULE & COMPANY LTD/MSTC LTD. Hence the bidders are required to ensure that their corporate email I.D. provided is valid and updated at the stage of registration of vendor with MSTC. Bidders are also requested to ensure validity of their DSC (Digital Signature Certificate).

Any order resulting from this open e-tender shall be governed by the terms and conditions mentioned therein.

No deviation to the technical and commercial terms & conditions are allowed.

ANDREW YULE & COMPANY LTD/ Rajgarh Tea Estate has the right to cancel this e-Tender without assigning any reason thereof.

The online tender should be submitted strictly as per the terms and conditions and procedures laid down in the website [www.mstcecommerce.com/eprochome/aycl](http://www.mstcecommerce.com/eprochome/aycl) of MSTC Ltd.

The bidders must upload all the documents required as per terms of NIT. Any other document uploaded which is not required as per the terms of the NIT shall not be considered.

The bid will be evaluated based on the filled-in technical & commercial formats.

Bidders are requested to read the vendor guide and see the video in the page [www.mstcecommerce.com/eprochome/mstc](http://www.mstcecommerce.com/eprochome/mstc) of MSTC Ltd. to familiarize them with the system before bidding.

**Notice Inviting Tender:**

**Ref. E-Tender No.:** AYCL/TEA DIVISION/29/17-18/ET/155

**Ref. Tender No.:** RJ/CAPITAL/17-18/01

Rajgarh Tea Estate on behalf of Andrew Yule & Co. Ltd., Tea Division, wishes to Renovate the Welfare Officer's Bungalow of Rajgarh Tea Estate located in the State of Assam in Dibrugarh District.

Offers are invited from reputed contractors for wiring at specified locations.

Contractors interested to participate in the above Tender will have to :

- a) Get themselves registered (free of cost) as supplier with [www.mstcecommerce.com/eprochome/aycl](http://www.mstcecommerce.com/eprochome/aycl), our service provider.
- b) Submit the following document to Rajgarh Tea Estate, Dibrugarh, Assam 785611 within 21 days from the date of publication of advertisement, off line -
  - General Information Sheet complete in all respect duly signed and stamped.
  - Earnest money of Rs.4,500/- by Draft favouring Andrew Yule & Co. Ltd. A/C Rajgarh Tea Estate payable at Dibrugarh.
  - Commercial Terms & Conditions Sheet, duly signed and stamped as token of acceptance.
  - Technical specification sheet, with all desired details, duly signed and stamped as token of acceptance.

The following pre-qualification criteria would apply, which may be relaxed at the sole discretion of Andrew Yule & Co. Ltd. / Rajgarh Tea Estate.

The Bidder should have minimum 4 years of constructions experience and holding authority to deal with Andrew Yule & Co. Ltd./Dibrugarh Tea Estates. This should be supported by appropriate documentary evidence.

The Bidder shall be a registered Company and posses valid sales tax / GST registration/ service tax registration certificates.

The OEM/Bidder should have own local support office / franchisee presence for the locations namely Golaghat / Jorhat and should be able to provide a Service Engineer as and when required.

GST registration is mandatory. Without GST registration the bidding(Part I) will be disqualified.



**General Information****Ref. E-Tender No.:** AYCL/TEA DIVISION/29/17-18/ET/155**Ref. Tender No.:** RJ/CAPITAL/17-18/01

The applicants are required to furnish full information to the queries included in this form. In giving the particulars, the supporting documents/certificates as called for per queries at places, must be tagged with the application for evidencing the information furnished in the application.

**1. Particulars of Company**

- 1.1 Name of the Company :
- 1.2 Nature of business : OEM / Dealer / Distributor
- 1.3 Full address :
- 1.4 Phone No. :
- 1.5 Fax No. :
- 1.6 E-mail ID :

**2. Details of Certificate**

Sl No.	Particulars	Registration No.	Remarks
1.	Income Tax		Copy of Registration Certificate / PAN Card to be attached
5.	Trade Licence		Copy to be attached
5.	GST		Copy to be attached

**3. List of Local Office**

Sl. No	Location	Type of Centre		Bidders to Provide full address & Telephone No
		Company Operated	Franchised	

**4. Details of Banker**

1	Name of the Bank	
2	Name of the Branch	
3	Branch Code	
4	Address	
5	IFSC Code No.	
6	Account No.	

5. List of supplies of identical :  
items made in last 2 years.  
with customer reference

6. Copies of Purchase Orders :  
received from major Customer  
for identical type of items  
(minimum 2 order copies)

I/we hereby certify that the particulars furnished by me/us above are true to the best of my / our knowledge and belief and mis-representations of facts will render me/us liable to my/our action as may be deemed fit by Andrew Yule & Co. Ltd. (Tea Division) / RajgarhTea Estate& have the sole discretion to reject or accept my/our candidature.

Signature of the Applicant)  
Office Stamp/Seal.

Place :

Date ;

List of Enclosures :

**General Terms& Conditions**

**Ref. E-Tender No.:** AYCL/TEA DIVISION/29/17-18/ET/155

**Ref. Tender No.:** RJ/CAPITAL/17-18/01

**Scope of Work**

Supply/Renovation of Welfare Officer's Bungalow as mentioned below and as per the approved drawing, specification and bill of materials.

**Requirement**

Renovation & Repairing of Welfare Officer's Bungalow.

1. **Delivery**

The entire material/all the items within 03 months from the date of receipt of order.

2. **Liquidated Damage**

In the event of failure on the part of the contractor to complete entire work against the order to our full satisfaction within the specified period of completion, we may recover from the contractor as liquidated damages, a sum equivalent to ½% of contract value for each week or any part thereof default, where the delivery thereof will be accepted after expiry of the date stipulated for this purpose, but limited to a maximum of 10% of contract value

3. **Force Majeure**

Any delay or failure in the performance of either party hereto will not constitute default there under or give rise to any claim for damages, if any, to the extent such delays or failure of performance is caused by the occurrence such as acts of god or the public enemy, appropriation or confiscation of facilities by Govt. Authorities, acts of war, rebellion or sabotage, fires, explosions, riots and illegal strike.

4. **Risk Purchase**

In case the contractor fails to execute the contract fully or partly, the purchaser shall have the right to execute the work through other agencies, as decided by the purchaser at the contractor's cost and risk after giving two weeks' notice in writing.

5. Terms of payment

- No advance will be given.
- Part payment to be released according to the progress of work with 10% retention at each stage described in the scope of work which will be returned after 1 year of completion of the project.
- Statutory deductions will be made as per the rules.

6. Price Variation

The quoted price should remain firm during pendency of the contract.

7. Guarantee

Written warranty of 12(Twelve) months to be to be given for the entire construction/Renovation.

8. The tenderers are requested to ensure Earnest Money Deposit along with the Tender in the following manner, which will be converted into Security Deposit for the successful bidder/s and will be released on completion of delivery.

**EMD Amount ---- Rs.4,500/-**

EMD to be submitted by D.D. favouring **Andrew Yule & Co. Ltd.-A/c. Rajgarh Tea Estate**, payable at Dibrugarh

9. Decision for awarding contract/job is vested with the Management so as to reject, split / fragment.
10. Incomplete "Quotation/Offer" is liable to be rejected.
11. The offer must be valid for our acceptance for 90 days from the date of E- bidding.
12. All materials to be routed through Garden stores only.
13. All applicable Taxes will be deducted at source as per statute
14. Legal disputes if any will be subjected to Dibrugarh jurisdiction only
15. During the constructions, the Management/ authorized representative(s) of the Management will have the right of inspection at any time during working hours.
16. Temporary shelter, water for construction & workers will be provided by the Management and if feasible / possible temporary electricity may be provided subject to Management's sole discretion.
17. I/We agree to the terms and conditions of LIQ.

I /We here by certify that the above particulars furnished by me /us above are true to the best of my/our knowledge and belief and misrepresentations of facts will render me / us liable to any action as may be deemed fit by Andrew Yule & Co. Ltd's Tea Division to reject or accept my / our Bid in totality.

(Sign & Seal of Applicant)

**Ref. E-Tender No.:** AYCL/TEA DIVISION/29/17-18/ET/155

**Ref. Tender No.:** RJ/CAPITAL/17-18/01

**Technical specification and requirement**

- A.** Extension of Bed Room : Excavation of earth work in foundation of wall and column for extension of room, 10'' Brick work up to Plinth level, 5'' brick work up to ceiling level, RCC column in 1:2:4, Earth filling, Brick soiling under floor, PCC with neat cement polish, plaster on wall, Doors and windows fitting, Roof with timber and AC sheet AC board ceiling, painting, Electrical wiring with copper wire, ceiling fan etc. complete -----1 Job.
- B.** Repairing & Renovation of ceiling : dismantling of existing ceiling with board and false, levelling the new false ceiling after replacing damaged timber, applying wood care oil, refitting of AC Board, with beading painting complete.....1 Job.
- C.** Construction of Car porch:
  - 1. Providing 2 nos. RCC post 9''x9'' size, flooring with brick soiling with PCC on it with 1:2:4
  - 2. Fitting of Truss & Purline with m.s.48mm OD pipe, CGI Roofing sheet.
- D.** Construction of Periphery Drain :
  - 1. earth work in digging & levelling to maintain proper slope of new drain with plinth apron 2' wide with flat brick soiling, ramming etc.as shown in the drawing.
  - 2. PCC 1:2:4 and neat cement plaster on soiling after filling the gap with slurry including drain side and bed.

## ANDREW YULE &amp; COMPANY LIMITED

**Rajgarh Tea Estate****Ref. E-Tender No.:** AYCL/TEA DIVISION/29/17-18/ET/155**Ref. Tender No.:** RJ/CAPITAL/17-18/01**Bill of Materials**Garden: Rajgarh Tea Estates of Assam.

Item: Renovation of Welfare Officer's Bungalow

Sl. No	Particular of Item	Brand	Specification	Unit	Quantity	Unit Rate	GST	Total Amount
						Rs.	%	
1	Bricks	1 <sup>st</sup> Class	NA	Pcs.	8000			
2	Cement	Topcem	NA	Bags	102			
3	Sand	NA	Fine	CFT	700			
4	Stone	NA	3/8"	CFT	330			
5	Brocken Bricks	NA	NA	CFT	100			
6	M.S. rod	ISI mark	12,10,8,6 mm	Kg	196			
7	M.S. Pipe	ISI mark	48 mm OD	Kg	110			
8	Timber	1 <sup>st</sup> Class	NA	CFT	65			
9	A.C. Sheet	Rhino	2.75 mtr.	Mtr	54			
10	A.C. Riding	Rhino		Mtr.	12			
11	CGI Sheet	Tata Sakti	0.5mm	Ft.	84			
12	Shuttering Timber	NA	NA	CFT	12			
13	Window	Steel fabricated	5'x4' 3 palla	No	2			
14	Window	Steel fabricated	3'x4' 2 palla	No	1			
15	Flush door with frame	NA	3'x7'	No	2			
16	Binding Wire	NA	NA	Kg	5			
17	Distemper	Asian Paint	NA	Kg	100			
18	Synthetic Paint	Asian	NA	Lt.	4			
19	Wood care oil	Lion	NA	Lt.	15			
20	Exterior paint (Cement)	Asian	NA	Kg.	25			
21	Thinner	Lion	NA	Lt.	2			
22	Glass	NA	4mm	Sq.ft	52			
23	Putty	NA	NA	Kg	15			
24	Earth filling			Trip	3			
25	Light plung point wiring with 1.5 & 2.5 mm 2 copper wire with PVC casing , swutch & board etc complete fitting	ISI	NA	Points	8			
26	Hardware goods	NA	LS					
27	Labour Charge							

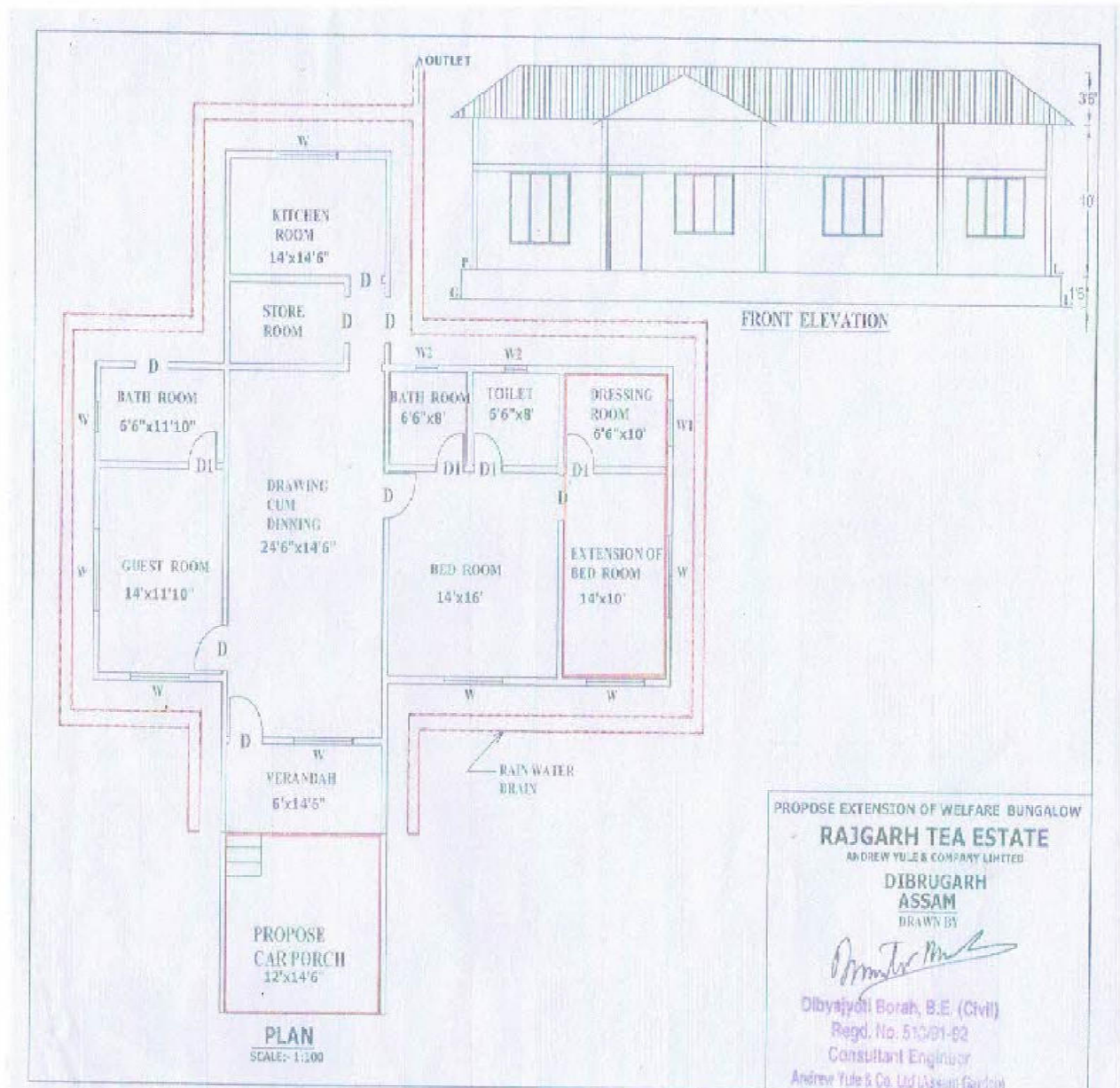

EXISTING ROOF

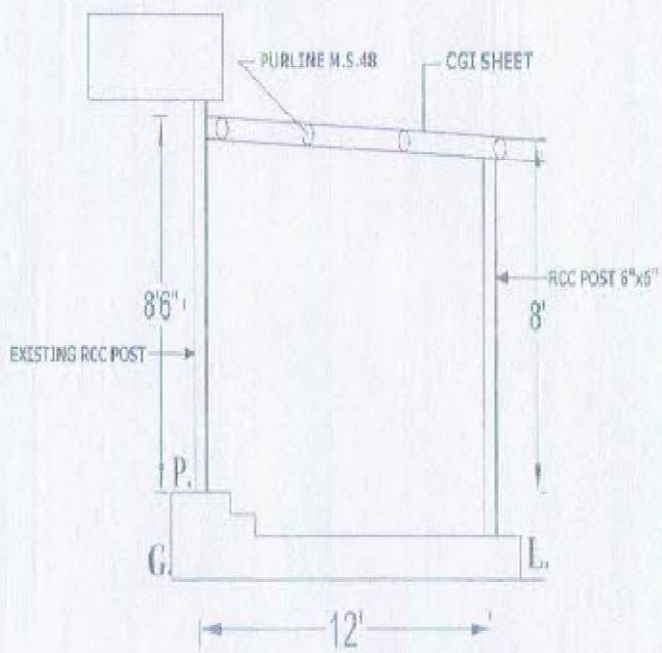

SIDE ELEVATION  
SCALE:- 1:50

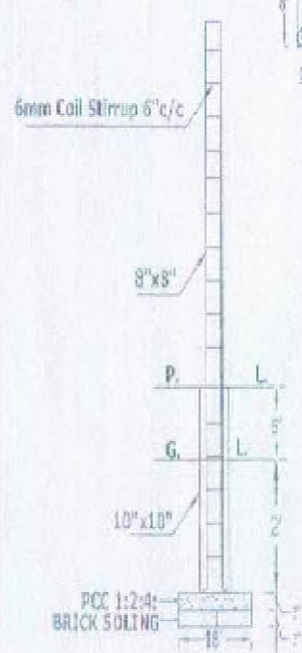
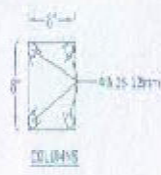

DETAILS OF COLUMN & FOOTING

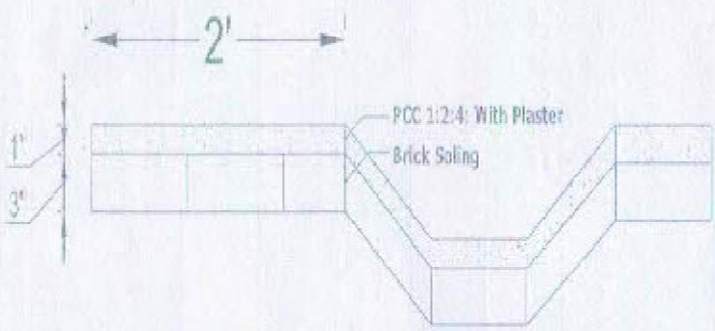

PROPOSE PERIPHERY DRAIN

PROPOSE EXTENSION OF WELFARE BUNGALOW

**RAJGARH TEA ESTATE**

ANDREW YULE & COMPANY LIMITED

**DIBRUGARH  
ASSAM**

DRAWN BY

Dibyajyoti Borah, B.E. (Civil)  
Regd. No. 513/91-92  
Consultant Engineer  
Andrew Yule & Co. Ltd (Assam Chapter)



ANDREW YULE & COMPANY LIMITED  
**Rajgarh Tea Estate**  
**Price sheet for Renovation of W/O Bungalow**

**Ref. E-Tender No.:** AYCL/TEA DIVISION/29/17-18/ET/155

**Ref. Tender No.:** RJ/CAPITAL/17-18/01

**PRICE SHEET**

Garden: Group Tea Estates of Assam.

Item: **Renovation of W/O Bungalow**

Quantity Offered	Unit	<u>Renovation of W/O Bungalow</u>	GST As applicable	Unit Site Cost	Contract Price
		Rs.	Rs.	Rs.	Rs.
1 unit					